

SmallRig

User Manual

用户手册

Bedienungsanleitung

Manuel d'utilisation

Manuale dell'utente

Manual del usuario

Manual do usuário

Gebruiksaanwijzing

Gebruikershandleiding

사용자 설명서

ユーザーマニュアル

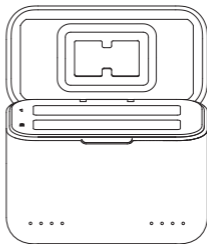

Camera Battery Charger

for Insta360 X5

相机电池充电器 (适配于影石 360 X5)



CONTENTS

Important Reminder	01
重要提示	01
Wichtige Hinweise	02
Remarques importantes	02
Promemoria Importante	03
Importante aviso	03
Importante Aviso	04
Belangrijke instructies	04
Viktig prompt	05

EN

Product Introduction	06
Instructions for Use	07
Battery Level indicator Light	07
Specifications	08
Usage Notes	08

CN

产品介绍	09
使用介绍	10
电量指示灯	10
规格参数	11
使用注意	11

DE

Produkte	12
Gebrauchsanweisung	13
Batteriestandanzeige	13
Specifications	14
Hinweise zur Verwendung	14

FR

Aperçu du produit	15
Étapes d'installation	16
Paramètres du produit	16
Specifications	17
Hinweise zur Verwendung	17



CONTENTS

IT

Descrizione del prodotto	19
Introduzione all'uso	20
Indicatore del livello della	20
Specifications	21
Avvertenze per l'uso	21

ES

Introducción del producto	21
Instrucciones de uso	22
Luz indicadora de nivel de batería	22
Specifications	23
Precauciones de uso	23

PT

Apresentação do produto	24
Instruções de uso	25
Indicador de carga de bateria	25
Especificações	26
Precauções de uso	26

NL

Productinleiding	27
Gebruiksaanwijzing	28
Batterijniveau indicatorlamp	28
Specificatie	29
Gebruiksopmerkingen	29

SE

Produktbeskrivning	30
Användningsinstruktioner	31
Indikatorlampa för batterinivå	31
Specifikationer	32
Användningsanvisningar	32

 Service & Warranty / 保修条款	33 - 34
Guarantee Card / 保修卡	35

EN

Thank you for choosing SmallRigs products.

Important Reminder

- Please keep the product dry and avoid contact with water or other liquids.
- Do not use the product in high temperature, humid, or dusty environments.
- Keep the product away from flammable materials and avoid prolonged use.
- If any damage is found on the product, please stop using it immediately and contact the after-sales service department for repair or replacement.

CN

感谢您购买 SmallRig 产品。

重要提示

- 请保持产品干燥，避免接触水或其他液体。
- 请勿在高温、潮湿或多尘的环境中使用产品。
- 请勿将产品置于易燃物品附近，并避免长时间使用。
- 若发现产品有任何损坏，请立即停止使用并联系售后服务部门进行维修或更换。

DE

Vielen Dank für den Kauf von SmallRig Produkten.

Wichtige Hinweise

- Bitte halten Sie das Produkt trocken und vermeiden Sie den Kontakt mit Wasser oder anderen Flüssigkeiten.
- Verwenden Sie das Produkt nicht in Umgebungen mit hoher Temperatur, Feuchtigkeit oder Staub.
- Halten Sie das Produkt weg von entflammaren Materialien und vermeiden Sie die langandauernde Nutzung.
- Wenn Schäden am Produkt festgestellt werden, hören Sie sofort auf es zu verwenden und wenden Sie sich an den Service für Kundenservice für Reparatur oder Austausch.

FR

Merci d'avoir acheté un produit SmallRig.

Remarques importantes

- Veuillez garder le produit sec et éviter tout contact avec l'eau ou d'autres liquides.
- N'utilisez pas le produit dans des environnements à forte température, humides ou poussières.
- Tenez le produit à l'écart des matières inflammables et évitez une utilisation prolongée.
- Si des dommages sont détectés sur le produit, veuillez cesser son utilisation immédiatement et contacter le service après-vente pour une réparation ou un remplacement.

IT

Grazie per aver acquistato il prodotto di SmallRig.

Suggerimento importante

- Mantenete il prodotto asciutto e evitate il contatto con l'acqua o altri liquidi.
- Non utilizzare il prodotto in ambienti ad alta temperatura, umidi o polverosi.
- Tieni il prodotto lontano da materiali infiammabili e evita l'uso prolungato.
- Se si riscontrano danni sul prodotto, smettete immediatamente di utilizzarlo e contattate il reparto assistenza clienti per la riparazione o il cambio.

ES

Gracias por adquirir los productos de SmallRig.

Advertencia:

- Mantenga el producto seco y evite el contacto con agua u otros líquidos.
- No utilice el producto en ambientes de alta temperatura, humedad o polvo.
- Mantenga el producto alejado de materiales inflamables y evite el uso prolongado.
- Si nota cualquier daño en el producto, deje de usarlo de inmediato y comuníquese con el departamento de servicio postventa para la reparación o el reemplazo.

PT

Obrigado por escolher produto SmallRig.

Informações Importantes:

- Mantenha o produto seco e evite contato com água ou outros líquidos.
- Não use o produto em ambientes de alta temperatura, úmido ou poeirento.
- Mantenha o produto longe de materiais inflamáveis e evite o uso prolongado.
- Se detectar qualquer dano no produto, pare de usá-lo imediatamente e contate o departamento de serviço pós-venda para reparo ou substituição.

NL

Bedankt voor uw keuze voor SmallRig-producten.

Belangrijke herinnering

- Houd het product droog en vermeid contact met water of andere vloeistoffen.
- Gebruik het product niet in omgevingen met hoge temperaturen, vochtigheid of stof.
- Houd het product ver van brandbare materialen en vermeid langdurig gebruik.
- Als enige schade aan het product wordt geconstateerd, stop onmiddellijk met het gebruiken en neem contact op met de klantenservice voor reparatie of vervanging.

Tack för att du väljer SmallRig-produkter.

Viktig påminnelse

- Håll produktet torrt och undvik kontakt med vatten eller andra vätskor.
- Använd inte produkten i miljöer med hög temperatur, fuktighet eller damm.
- Håll produktet borta från brandbara material och undvik långvarig användning.
- Om någon skada på produkten upptäckts, sluta omedelbart att använda det och kontakta kundtjänst för reparation eller ersättning.

Product Introduction

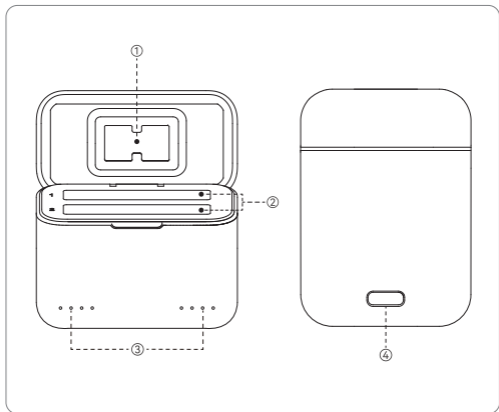

① TF Cards Slot

② Battery Charging Slot

③ Power Indicator

④ USB-C Charging Port





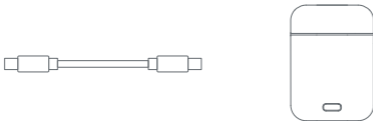

Instructions for Use

Insert the battery into the slot. Connect the charging case using a USB-C cable. Plug in the power supply to start charging.



Battery Level Indicator Light

- * When a battery is inserted, the LED will display the battery level.
- * If the battery is already in the charging case, opening the lid will display the battery level.
- * When connected to power, the LEDs act as charging indicators.

	Flashing Light	Charging in progress
	1 Light Flashing	Battery level below 30%
	1 Solid Light	≈ 30%
	2 Solid Lights	≈ 50%
	3 Solid Lights	≈ 75%
	4 Solid Lights	100% charged

Specifications

Model	CH-X1
USB-C Input	5V \Rightarrow 3A, 9V \Rightarrow 2A, 12V \Rightarrow 1.5A
Output (per channel)	4.48V \Rightarrow 1A
Charging Channels	2
TF Card Slots	2
Operating Temperature	0°C to 40°C (32 °F to 104 °F)
Product Dimensions	76.0 × 60.0 × 43.0mm / 3.0 × 2.36 × 1.69in
Product Weight	84.0 ± 5.0g / 2.96 ± 0.2oz

Usage Notes:

1. Do not drop the charger or place heavy objects on it.
2. Children should only use this charger under adult supervision.
3. Use the charger only within the specified temperature range: 0°C to 40°C (32°C to 104°F).
4. Do not use or store the charger in direct sunlight, near heat sources, or in high-temperature environments.
5. During charging, do not cover the charger with items such as towels or clothing, as this may cause a fire.
6. When not in use, remove the battery from the charger to prevent battery drain.

产品介绍

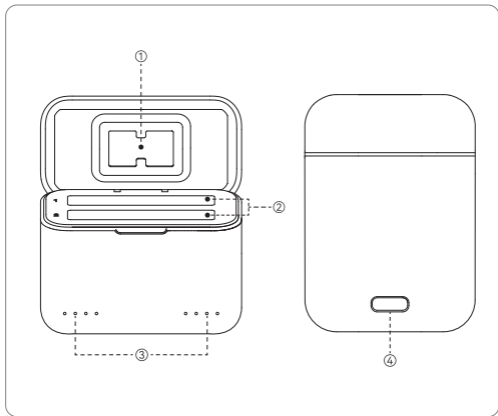

① TF 卡收纳位

② 电池充电仓

③ 充电指示灯

④ USB-C 充电口

使用介绍

请将电池放入电池槽，然后用 USB-C 线连接充电盒，插上电源即可充电。



电量指示灯

- * 放入电池，LED 灯直接显示电量。
- * 若电池已在盒内，打开上盖，LED 灯直接显示电量。
- * 连接电源状态，则为充电指示灯。

	灯闪烁	正在充电
	一格灯闪烁	低于30%电量
	一格灯	≈ 30% 电量
	两格灯	≈ 50% 电量
	三格灯	≈ 75% 电量
	四格灯	≈ 100% 电量

规格参数

型号	CH-X1
USB-C 输入	5V = 3A, 9V = 2A, 12V = 1.5A
输出(每通道)	4.48V = 1A
充电通道	2 个
TF 卡收纳位	2 个
工作环境温度	0°C ~ 40°C (32 °F ~ 104 °F)
产品尺寸	76.0 × 60.0 × 43.0mm / 3.0 × 2.36 × 1.69in
产品重量	84.0 ± 5.0g / 2.96 ± 0.2oz

使用注意:

1. 请勿使充电器落地或将重物置于其上。
2. 儿童须成人的监督下使用本充电器。
3. 须在 0°C ~ 40°C 温度范围内使用本充电器。
4. 请勿在直射阳光下、发热的设备旁或其它高温场所使用或储存本充电器。
5. 在充电过程中, 请勿用如毛巾、衣服之类的物品将充电器掩盖, 避免导致火警。
6. 在不使用充电器时, 请将充电器内的电池取出, 以免造成电池电量损耗。

DE

Produkte

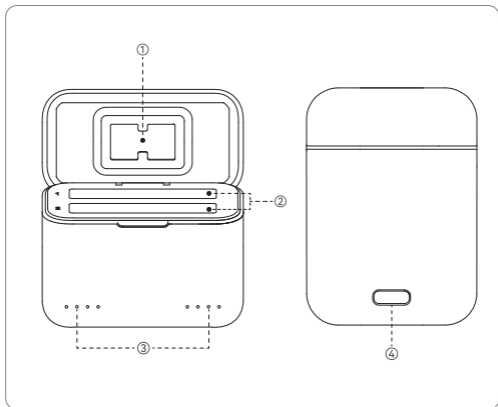

① TF-Kartenfach

② Ladebox

③ Ladeanzeige

④ USB-C-Ladeanschluss







Gebrauchsanweisung

Setzen Sie die Batterie in das Batteriefach ein, verbinden Sie dann das Lade-case mit einem USB-C-Kabel und schließen Sie das Netzteil an, um den Ladevorgang zu starten.



Batteriestandanzeige

- * Beim Einsetzen der Batterie zeigen die LEDs direkt den Batteriestand an.
- * Wenn sich die Batterie bereits im Fach befindet, öffnen Sie den Deckel und die LEDs zeigen direkt den Batteriestand an.
- * Bei angeschlossener Stromversorgung dienen die LEDs als Ladeanzeige.

	LEDs blinken	Wird geladen
	Eine LED blinkt	Batteriestand unter 30%
	Eine LED	≈ 30% Batteriestand
	2 solid lights	≈ 50% Batteriestand
	3 solid lights	≈ 75% Batteriestand
	4 solid lights	= 100% Batteriestand

Spezifikationen

Modell	CH-X1
USB-C-Eingang	5V = 3A, 9V = 2A, 12V = 1.5A
Ausgang (pro Kanal)	4,48V = 1A
Aufladungskanal	2 Stück
TF-Kartenfach	2 Stück
Betriebstemperatur	0 °C bis 40 °C (32 °F bis 104 °F)
Produktgröße	76,0 × 60,0 × 43,0mm / 3,0 × 2,36 × 1,69in
Produktgewicht	84,0 ± 5,0g / 2,96 ± 0,2oz

Hinweise zur Verwendung:

1. Lassen Sie das Ladegerät nicht fallen und stellen Sie keine schweren Gegenstände darauf.
2. Kinder dürfen dieses Ladegerät nur unter Aufsicht von Erwachsenen verwenden.
3. Verwenden Sie dieses Ladegerät nur im Temperaturbereich von 0 °C bis 40 °C (32 °F bis 104 °F).
4. Verwenden oder lagern Sie das Ladegerät nicht in direktem Sonnenlicht, in der Nähe von Wärmequellen oder an anderen Orten mit hohen Temperaturen.
5. Decken Sie das Ladegerät während des Ladevorgangs nicht mit Gegenständen wie Handtüchern oder Kleidung ab, um Brandgefahr zu vermeiden.
6. Entfernen Sie die Batterie aus dem Ladegerät, wenn es nicht in Gebrauch ist, um die Entladung der Batterie zu verhindern.

Introduction du produit

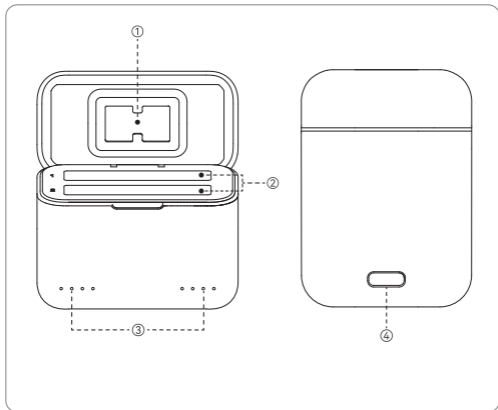

① Emplacement pour
carte TF

② Compartiment de
charge de la batterie

③ Voyant de charge

④ Port de charge USB-C







Mode d'emploi

Placez la batterie dans le logement prévu à cet effet, puis connectez le boîtier de charge avec un câble USB-C et branchez l'alimentation pour démarrer la charge.



Voyant de niveau de batterie

- *Lorsque la batterie est insérée, le voyant LED affiche directement le niveau de batterie.
- *Si la batterie est déjà dans le boîtier, ouvrez le couvercle supérieur et le voyant LED affichera directement le niveau de batterie.
- *Lorsqu'il est connecté à l'alimentation, il s'agit du voyant de charge.

	Clignotement du voyant	En charge
	Une section clignotant	niveau de batterie inférieur à 30 %
	Une section allumée	environ 30 % du niveau de batterie
	Deux sections allumées	environ 50 % du niveau de batterie
	Trois sections allumées	environ 75 % de niveau de batterie
	Quatre sections allumées	environ 100 % de niveau de batterie

Spécifications

Modèle	CH-X1
Entrée USB-C	5V = 3A, 9V = 2A, 12V = 1.5A
Sortie (par canal)	4,48V = 1A
Canaux de charge	2 unités
Emplacement pour carte TF	2 unités
Température de travail	0°C à 40°C (32 °F à 104 °F)
Taille du produit	76,0 × 60,0 × 43,0mm / 3,0 × 2,36 × 1,69in
Poids du produit	84,0 ± 5,0g / 2,96 ± 0,2oz

Précautions d'utilisation:

1. Ne laissez pas le chargeur tomber par terre ou placez des objets lourds dessus.
2. Les enfants doivent utiliser ce chargeur sous la surveillance d'un adulte.
3. Utilisez ce chargeur dans une plage de température de 0 à 40 °C (32 à 104 °F).
4. N'utilisez ou ne stockez pas ce chargeur en plein soleil, à proximité d'appareils chauffants ou dans d'autres endroits à haute température.
5. Pendant la charge, ne couvrez pas le chargeur avec des objets tels que des serviettes ou des vêtements pour éviter tout risque d'incendie.
6. Lorsque le chargeur n'est pas utilisé, retirez la batterie du chargeur pour éviter une perte de niveau de batterie.

Descrizione del prodotto

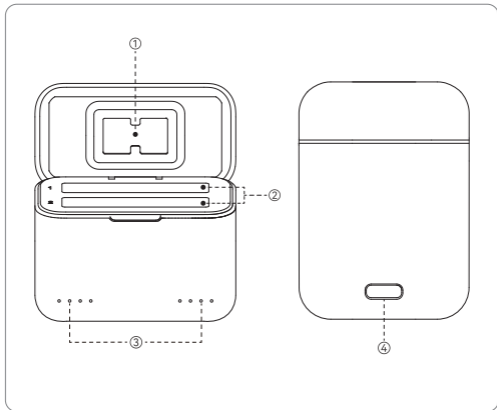

① Alloggiamento per scheda TF

② Comparto di ricarica della batteria

③ Spia di carica

④ Porta di ricarica USB-C

Introduzione all'uso

Inserire la batteria nello slot, quindi collegare la scatola di ricarica con un cavo USB-C e inserire la spina per avviare la carica.



Indicatore del livello della batteria

- *Inserire la batteria e la spia LED mostrerà direttamente il livello di potenza.
- *Se la batteria è già all'interno della scatola, aprire il coperchio superiore e la spia LED mostrerà direttamente il livello di potenza.
- *Se collegato all'alimentazione, funge da spia di carica.

	Spia lampeggiante	Ricaricando
	Una spia lampeggiante	livello di potenza inferiore al 30%
	Una spia	≈ 30% livello di potenza
	Due spie	≈ 50% livello di potenza
	3 spie	≈ 75% livello di potenza
	4 spie	= 100% livello di potenza

Specifiche

Modello	CH-X1
Ingresso USB-C	5V = 3A , 9V = 2A , 12V = 1.5A
Uscita (per canale)	4,48V = 1A
Canale di carica	2 pezzi
Alloggiamento per scheda TF	2 pezzi
Temperatura di lavoro	0°C a 40°C (32 °F a 104 °F)
Dimensioni del prodotto	76,0 × 60,0 × 43,0mm / 3,0 × 2,36 × 1,69in
Peso del prodotto	84,0 ± 5,0g / 2,96 ± 0,2oz

Avvertenze per l'uso:

1. Non far cadere il caricabatterie o posizionare oggetti pesanti su di esso.
2. I bambini devono utilizzare questo caricabatterie sotto la supervisione di un adulto.
3. Utilizzare questo caricabatterie nell'intervallo di temperatura da 0°C a 40°C (32°F a 104°F).
4. Non utilizzare o conservare il caricabatterie alla luce diretta del sole, vicino a dispositivi che emettono calore o in altri ambienti ad alta temperatura.
5. Durante la carica, non coprire il caricabatterie con oggetti come asciugamani o indumenti per evitare il rischio di incendio.
6. Quando il caricabatterie non è in uso, rimuovere la batteria al suo interno per evitare la perdita del livello di potenza.

Introducción del producto

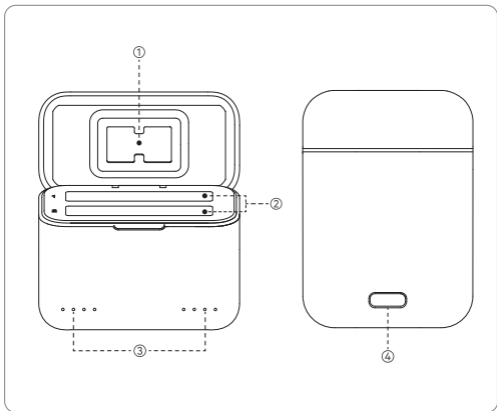

① Ranura para tarjeta TF

② Compartimento de carga de batería

③ Indicador luminoso de carga

④ Puerto de carga USB-C

Instrucciones de uso

Coloque la batería en el compartimiento, luego conecte la base de carga con un cable USB-C y enchúfela a la fuente de alimentación para iniciar la carga.



Luz indicadora de nivel de batería

- * Al colocar la batería, los LEDs mostrarán directamente el nivel de carga.
- * Si la batería ya está en el interior, al abrir la tapa superior, los LEDs mostrarán directamente el nivel de carga.
- * Cuando está conectado a la fuente de alimentación, funciona como indicador luminoso de carga.

	Luz parpadeante	En proceso de carga
	Una luz parpadeante	nivel de batería inferior al 30%
	Una luz	≈ 30% de carga
	Dos luces	≈ 50% de carga
	Tres luces	≈ 75% de carga
	Cuatro luces	= 100% de carga

Especificaciones

Modelo	CH-X1
Entrada USB-C	5V = 3A , 9V = 2A , 12V = 1.5A
Salida (cada canal)	4,48V = 1A
Canal de carga	2 unidades
Ranura para tarjeta TF	2 unidades
Temperatura de funcionamiento	0°C a 40°C (32 °F a 104 °F)
Dimensiones del producto	76,0 × 60,0 × 43,0mm / 3,0 × 2,36 × 1,69in
Peso del producto	84,0 ± 5,0g / 2,96 ± 0,2oz

Precauciones de uso:

1. No deje caer el cargador al suelo ni coloque objetos pesados sobre él.
2. Los niños deben usar este cargador bajo la supervisión de un adulto.
3. Debe utilizar este cargador dentro de un rango de temperatura de 0°C a 40°C (32°F a 104°F).
4. No utilice ni almacene el cargador bajo luz solar directa, cerca de dispositivos que generen calor o en otros lugares con altas temperaturas.
5. Durante el proceso de carga, no cubra el cargador con artículos como toallas o ropa, para evitar riesgos de incendio.
6. Cuando no esté en uso, retire la batería del cargador para evitar la pérdida del nivel de batería.

Apresentação do produto

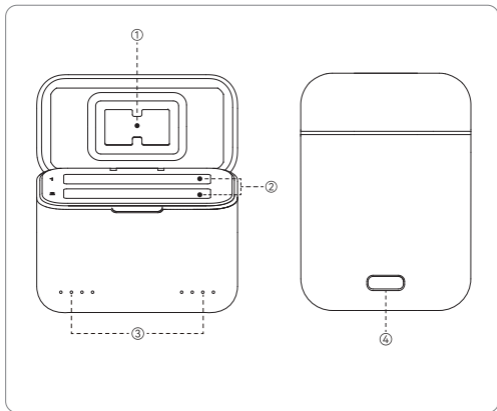

① Slot para cartão TF

② Compartimento de carregamento da bateria

③ Indicador de luz de carregamento

④ Porta de carregamento USB-C

Instruções de uso

Coloque a bateria no compartimento, conecte o estojo de carregamento com um cabo USB-C e ligue-o à fonte de alimentação para iniciar o carregamento.



Indicador de carga de bateria

- * Ao inserir a bateria, o LED exibirá diretamente o nível da bateria.
- * Se a bateria já estiver dentro da caixa, abra a tampa superior e o LED exibirá diretamente o nível da bateria.
- * Quando conectado à fonte de alimentação, o Indicador de luz mostrará o estado de carregamento.

	Luz piscando	Em carregamento
	Uma luz piscando	nível da bateria inferior a 30%
	Uma luz	≈ 30% do nível da bateria
	Duas luzes	≈ 50% do nível da bateria
	Três luzes	≈ 75% nível da bateria
	Quatro luzes	100% nível da bateria

Especificações

Modelo	CH-X1
Entrada USB-C	5V = 3A, 9V = 2A, 12V = 1.5A
Saída (por canal)	4,48V = 1A
Canal de carregamento	2 unidades
Slot para cartão TF	2 unidades
Temperatura de operação	0°C a 40°C (32°F a 104°F)
Dimensões do produto	76,0 × 60,0 × 43,0mm / 3,0 × 2,36 × 1,69in
Peso do produto	84,0 ± 5,0g / 2,96 ± 0,2oz

Precauções de uso:

1. Não deixe o carregador cair no chão ou coloque objetos pesados sobre ele.
2. As crianças devem usar este carregador sob supervisão de um adulto.
3. Este carregador deve ser utilizado dentro de uma faixa de temperatura de 0°C a 40°C (32°F a 104°F).
4. Não utilize ou armazene o carregador sob luz solar direta, próximo a equipamentos que geram calor ou em outros locais com temperaturas elevadas.
5. Durante o carregamento, não cubra o carregador com itens como toalhas ou roupas, para evitar riscos de incêndio.
6. Quando o carregador não estiver em uso, remova a bateria para evitar a perda de nível de carga.

Productinleiding

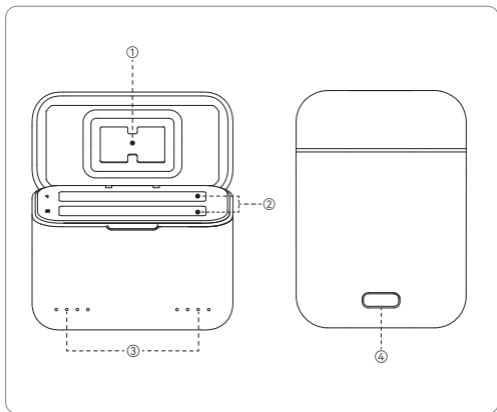

① TF-kaartsleuf

② Accu-ophlaadcompartiment

③ Laadindicator

④ USB-C-ophlaadpoort

Gebruiksaanwijzingen

Plaats de accu in de sleuf. Sluit de oplaadcase aan met een USB-C-kabel. Sluit de stroomvoorziening aan om het opladen te starten.

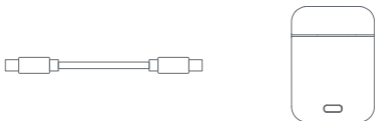

Batterijniveau indicatorlamp

- * Wanneer een accu is geplaatst, geeft de LED het accuniveau weer.
- * Als de accu al in de oplaadcase zit, geeft het openen van het deksel het accuniveau weer.
- * Wanneer aangesloten op stroom, fungeren de LED's als laadindicator.

	Knipperend licht	Bezig met opladen
	1 knipperend lampje	accuniveau onder 30%
	1 constante lampje	≈ 30% opgeladen
	2 constante lampjes	≈ 50% opgeladen
	3 constante lampjes	≈ 75% opgeladen
	4 constante lampjes	= 100% opgeladen

Specificaties

Model	CH-X1
USB-C-ingang	5V = 3A , 9V = 2A , 12V = 1.5A
Uitgang (per kanaal)	4,48V = 1A
Laadkanalen	2
TF-kaartsleuven	2
Bedrijfstemperatuur	0°C tot 40°C (32 °F tot 104 °F)
Productafmetingen	76,0 × 60,0 × 43,0mm / 3,0 × 2,36 × 1,69in
Productgewicht	84,0 ± 5,0g / 2,96 ± 0,2oz

Gebruiksaanmerkingen:

1. Laat de lader niet vallen en plaats er geen zware voorwerpen op.
2. Kinderen mogen deze lader alleen onder toezicht van een volwassene gebruiken.
3. Gebruik de lader uitsluitend binnen het opgegeven temperatuurbereik: 0°C tot 40°C (32°F tot 104°F).
4. Gebruik of bewaar de lader niet in direct zonlicht, nabij warmtebronnen of in omgevingen met hoge temperaturen.
5. Bedek de lader tijdens het opladen niet met voorwerpen zoals handdoeken of kleding, omdat dit brandgevaar kan veroorzaken.
6. Wanneer de lader niet wordt gebruikt, verwijderd u de accu om ontlading te voorkomen.

Produktbeskrivning

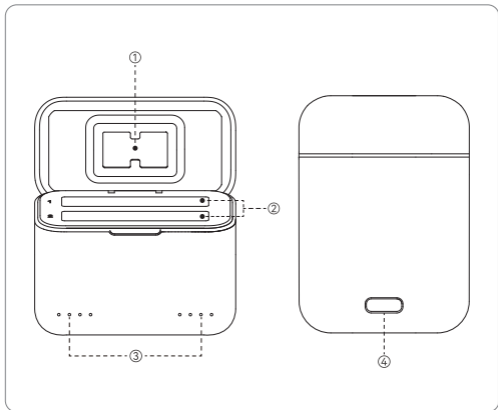

① TF-kortplatser

② Batteriladdningsfack

③ Laddningsindikator

④ USB-C laddningsport



Användningsinstruktioner

Sätt i batteriet i facket. Anslut laddningsfodralet med en USB-C-kabel. Anslut strömförsörjningen för att starta laddningen.



Indikatorlampa för batterinivå

- * När ett batteri är isatt visar LED-lampan batterinivån.
- * Om batteriet redan sitter i laddningsfodralet visas batterinivån när locket öppnas.
- * När strömkällan är ansluten fungerar LED-lamporna som laddningsindikatorer.

	Blinkande lampa	Laddning pågår
	1 blinkande lampa	batterinivå under 30%
	1 fast lampa	≈ 30% laddat
	2 fasta lampor	≈ 50% laddat
	3 fasta lampor	≈ 75% laddat
	4 fasta lampor	≈ 100% laddat

Specifikationer

Modell	CH-X1
USB-C-ingång	5V = 3A , 9V = 2A , 12V = 1.5A
Utgång (per kanal)	4,48V = 1A
Laddningskanaler	2
TF-kortplatser	2
Driftstemperatur	0°C till 40°C (32 °F till 104 °F)
Produktens mått	76,0 × 60,0 × 43,0mm / 3,0 × 2,36 × 1,69in
Produktens vikt	84,0 ± 5,0g / 2,96 ± 0,2oz

Användningsanvisningar :

1. Tappa inte laddaren och placera inte tunga föremål på den.
2. Barn får endast använda laddaren under uppsikt av en vuxen.
3. Använd laddaren endast inom det angivna temperaturområdet: 0°C (32°F) till 40°C (104°F).
4. Använd eller förvara inte laddaren i direkt solljus, nära värmekällor eller i miljöer med hög temperatur.
5. Täck inte över laddaren med föremål som handdukar eller kläder under laddning, eftersom detta kan orsaka brand.
6. Ta bort batteriet från laddaren när det inte används för att förhindra att batteriet laddas ur.

Service & Warranty

Please keep your original receipt and guarantee card. Be sure the dealer has written on it the date of purchase and SN of the product. These are required for warranty service.

After-sale Warranty Terms:

SmallRig products are entitled to warranty services as of the date of payment.

- **Electronic products (except V mount battery):** 1-year warranty.
- **V mount battery:** 2-year warranty.
- **Non-electronic products:** 2-year warranty.

Note: In case of any conflict between our warranty period policy and applicable laws and regulations of the country / region where the products are sold, the latter shall prevail.

This Warranty Does Not Cover:

- If users fail to adhere to the "Operating Instruction" or any "Warnings" stated in the user manual, resulting in a quality failure, it falls outside the scope of warranty coverage.
- The product identification or SN label is removed or defaced in any way.
- Product damage caused by problems not attributable to the quality of the products such as improper use of the products.
- Product damage caused by unauthorized modification, disassembly, repair and other acts.
- Product damage caused by fires, floods, lightning and other force majeure factors.

Warranty Mode:

- For the products within the scope of warranty, SmallRig will repair or replace them on the basis of specific failures; the repaired / replaced products / parts are entitled to the remaining part of the original warranty period.

Contact Information:

- You're advised to contact the online customer service personnel of corresponding shopping platform and submit a repair service application.
- You may also apply for repair service through SmallRig's service email.
Service Email: support@smallrig.com

保修条款

请保留您的原始购买单据及保修卡，同时包含您的购买日期、产品序列号等，这些资料质保服务时均需要提供。

☞ 售后质保条款：

SmallRig产品自下单付款之日起享有质保服务。

- 电子产品 (除V口电池)：1年质保。
- V口电池：2年质保。
- 非电子产品：2年质保。

注：若销售地国家或地区的适用法律法规有冲突的，以销售地国家或地区有关质保期的法律法规为准。

☞ 质保无效说明：

- 当用户违反操作指引或用户手册中“重要提示”任何一条导致的质量失效，不在质保范围内。
- 产品序列号标识已经被撕毁或无法辨识，不在质保范围。
- 产品使用不当等非产品本身质量问题，而造成的产品损坏，不在质保范围。
- 非官方指导的私自改装、拆解、维修等行为而造成的损坏，不在质保范围。
- 因火灾、水灾、雷击等不可抗力造成的产品损坏，不在质保范围。

☞ 维修方式：

- 属于质保范围的，SmallRig 根据产品具体的故障对产品进行维修或更换；维修后的产品 / 部件享受原有保修期的剩余时长。

☞ 联系方式：

- 建议您优先前往相应购买平台联系在线客服，提出产品维修申请。
- 您也可以通过 SmallRig 服务邮箱申请维修服务。

服务邮箱：support@smallrig.com

Guarantee Card

ID No.	
Item Name	
Purchase Date	
User Name	
Mobile	
Address	
Receipt	

保修卡

ID 编号	
产品名称	
购买日期	
用户姓名	
用户电话	
用户地址	
购买单据	

Manufacturer Email: support@smallrig.com

Manufacturer: Shenzhen Leqi Innovation Co., Ltd.

Add: Rooms 101, 701, 901, Building 4, Gonglianfuji Innovation Park, No. 58, Ping'an Road, Dafu Community, Guanlan Street, Longhua District, Shenzhen, Guangdong, China.

Consignor: Shenzhen LC Co., Ltd.

Add: Room 201, Building 4, Gonglianfuji Innovation Park, No. 58, Ping'an Road, Dafu Community, Guanlan Street, Longhua District, Shenzhen, Guangdong, China.

制造商: 深圳市乐其创新股份有限公司

地址: 中国广东省深圳市龙华区观澜街道大富社区平安路58号共联富基创新园4栋101、701、901

委托商: 深圳市乐长科技有限公司

地址: 中国广东省深圳市龙华区观澜街道大富社区平安路58号共联富基创新园4栋201



WE ARE HERE FOR YOU

服务与支持



ETICHETTATURA AMBIENTALE
ENVIRONMENTAL LABELING

执行标准: GB 4943.1-2022

LQ-B952-18



GAVIMOSA CONSULTORIA, SOCIEDAD
LIMITADA, CASTELLANA 9144, 28046 Madrid,
compliance.gavimosa@outlook.com



Sea&Mew Accounting Ltd,
Electric Avenue Vision 25, London,
Enfield EN3 7GD, info@seamew.net

CE FC RoHS



合格证
已检验

Séparez les éléments avant de trier



Points de collecte sur www.quefairedemesdechets.fr
Privilégiez la réparation ou le don de votre appareil !

Made in China | 中国制造

FREE YOUR DREAM

自 由 创 想