

# SmallRig

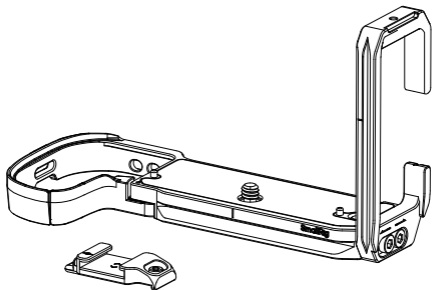

L-shaped Mount Plate (for Canon EOS R5 Mark II)

L型安装板(适用于佳能 EOS R5 MarkII)

Operating Instruction / 操作指引

- Thank you for purchasing SmallRig's product.  
感谢您购买 SmallRig 产品。
- Please read this Operation Guide carefully.  
使用本产品之前，请仔细阅读操作指引。
- Please follow the safety warnings.  
请注意所有警告提示并遵循使用操作指引的所有指令。

## In the Box / 包装清单

L-shaped Mount Plate	× 1	Allen Wrench	× 1
L型安装板		六角扳手	
Locating Block with Cold Shoe Mount	× 1	Guarantee Card	× 1
冷靴支撑压块		保修卡	

## Product Details / 产品介绍

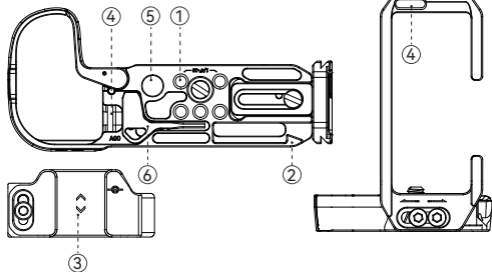

- |   |                            |
|---|----------------------------|
| ① 1/4"-20 Threaded Hole<br>1/4"-20 螺纹孔      | ④ Strap Slot<br>肩带 / 腕带接口  |
| ② Arca-Swiss Quick Release Plate<br>阿卡规格快装板 | ⑤ QD Socket<br>QD 接口       |
| ③ Cold Shoe Mount<br>冷靴                     | ⑥ Dual-Head Wrench<br>双头扳手 |

## L-Bracket Mounting Instruction / L型竖拍板安装步骤

### 1. Standard Mounting of the L-Bracket / 标准场景安装

Secure the L-shaped mounting plate and camera by tightening the bottom 1/4"-20 screw.

通过拧紧底部1/4"-20螺丝锁紧固定L型安装板和相机

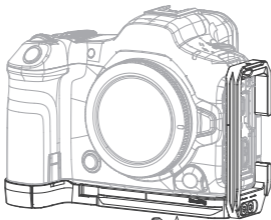

- \* The package does not include the camera
- \* 相机机身需另购



### 2. Mount the Extended L-Bracket / 拉伸场景安装

- 1 Move the side plate to the left.  
将侧板移动至最左侧。

- \* The package does not include the camera
- \* 相机机身需另购

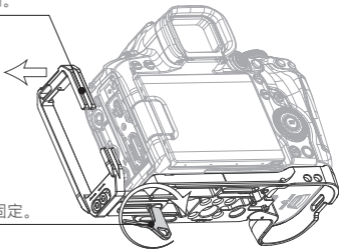

- 2 Secure it by the Dual-Head Wrench.  
通过双头扳手锁紧固定。

(2) Slide the Locating block into the camera strap slot from left to right, then fix it by tightening the screws.

将定位压块从左往右滑进相机肩带槽，通过锁紧螺丝固定。

1

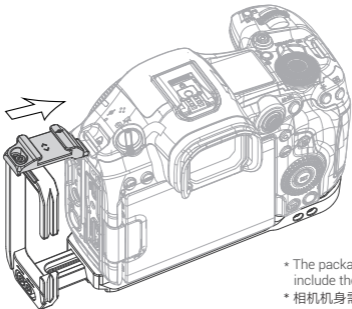

- \* The package does not include the camera
- \* 相机机身需另购

2

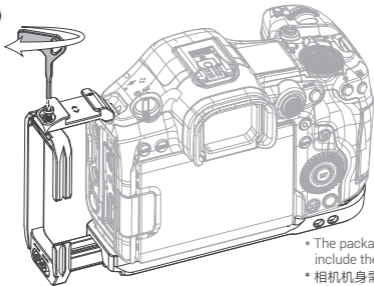

- \* The package does not include the camera
- \* 相机机身需另购

### 3.Side plate move forward and backward / 侧板前后移动

The side plate can adjust front and back by 5mm / 0.2in without obstructing the camera's side HDMI, microphone, and other interfaces.  
侧板可前后调整5mm / 0.2英寸，不会遮挡相机侧面的HDMI、麦克风等接口

1

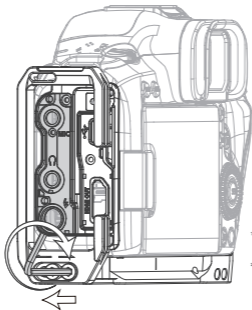

- \* The package does not include the camera
- \* 相机机身需另购

2

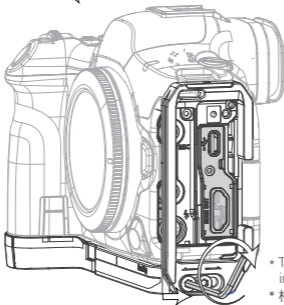

- \* The package does not include the camera
- \* 相机机身需另购

## Specifications / 产品参数

Product Dimensions 产品尺寸	5.90 × 2.60 × 3.5in 149.1 × 66.1 × 89.0mm
Product Weight 产品重量	5.35 ± 0.2oz 151.7 ± 5g
Material (s) 主要材质	Aluminum Alloy 铝合金

Manufacturer Email: support@smallrig.com

Manufacturer: Shenzhen Leqi Innovation Co., Ltd.

制造商: 深圳市乐其创新股份有限公司

Add: Rooms 101, 701, 901, Building 4, Gonglianfuji Innovation Park, No. 58, Ping'an Road, Dafu Community, Guanlan Street, Longhua District, Shenzhen, Guangdong, China.

地址: 中国广东省深圳市龙华区观澜街道大富社区平安路58号共联富基创新园4栋101、701、901

Consignor: Shenzhen LC Co., Ltd.

委托商: 深圳市乐长科技有限公司

Add: Room 201, Building 4, Gonglianfuji Innovation Park, No. 58, Ping'an Road, Dafu Community, Guanlan Street, Longhua District, Shenzhen, Guangdong, China.

地址: 中国广东省深圳市龙华区观澜街道大富社区平安路58号共联富基创新园4栋201

执行标准: GB/T 26572-2011

**RoHS**



中国制造  
Made in China

